

SCHEDA TECNICA -

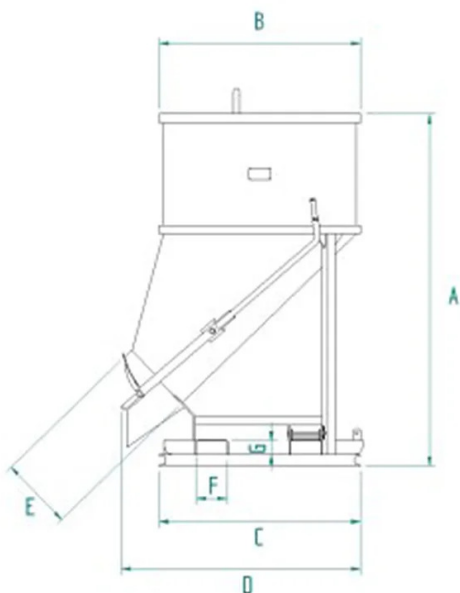

Settori di applicazione



COD. ART.	Portata (Kg)	Capacita' (L)	Peso (Kg)	DIMENSIONI (Mm)						
				A	B	C	D	E	F	G
BF-30ST	780	300	130	1185	935	935	1151	300	180	80
BF-40ST	1040	400	135	1350	935	935	1151	300	180	80
BF-50ST	1300	500	145	1510	935	935	1151	300	180	80
BF-75ST	1950	750	240	1781	1170	1170	1405	420	180	80
BF-99ST	2600	1000	250	2041	1170	1170	1405	420	180	80
BF-150ST	3900	1500	440	2025	1492	1492	1600	420	180	80
BF-200ST	5200	2000	500	2375	1492	1492	1600	420	180	80

* Note dimensioni - Possibilità di inserire una breve descrizione per specificare dei dettagli su alcune dimensioni